

## FIELD UNIT FOR 2 FIRE DAMPERS

- Connects 2 fire dampers to the bus
- Provides 2 plug connections for 24V actuators with ST-plug, such as ONE T24ST, BFLT24ST and BFNT24ST.
- Has a predefined address (no addressing required during system commissioning)
- AC 230 V mains power



## TECHNICAL DATA

ELECTRICAL DATA	
Nominal voltage	AC 230 V 50/60 Hz
Nominal voltage range	AC 100 ... 230 V
For wire sizing	24 VA
Power consumption from mains	Actuator consumption + 300 mW
Power consumption from bus	5 mW
Connecting	Power supply terminal 2 x 3 x max. 2.5 mm <sup>2</sup> (min. 0.5 mm <sup>2</sup> ) Actuator outputs Plug, 6 poles Actuator power supply Plug, 3 poles Bus terminal 2 x 4 x 1.5 mm <sup>2</sup> wire
SAFETY	
Protection class	Class II (all insulated)
Degree of protection	IP54
EMC	CE according to 2004/108/EC
Low-voltage-directive	CE according to 2006/95/EC
Ambient humidity range	IEC 60730-1 max. 95 %
Ambient temperature range	-20 ... +60 °C
Non-operating temperature	-40 ... +85 °C
Maintenance	Maintenance-free
DIMENSIONS / WEIGHT	
Dimensions	154 x 114 x 77 mm
Weight	400 g

## PRODUCT FEATURES

Control of fire damper actuators	ZENiX 2FDST is used for controlling up to two 24 V fire damper actuators with ST-plug. The unit is connected to the ZENiX controller module via a 4 wire bus communication.
Connection	The ST actuators are equipped with connectors that are plugged directly into the ZENiX 2FDST unit.
Isolation	The actuator is isolated from mains by a transformer.
Predefined address	Each unit has a predefined address, no addressing required.
Work without 230 V	The ZENiX 2FDST unit is able to work without 230 V: it will only send data about actuator positions to the ZENiX controller and will not be able to re-arm the fire dampers.

## WIRING AND RESOURCES

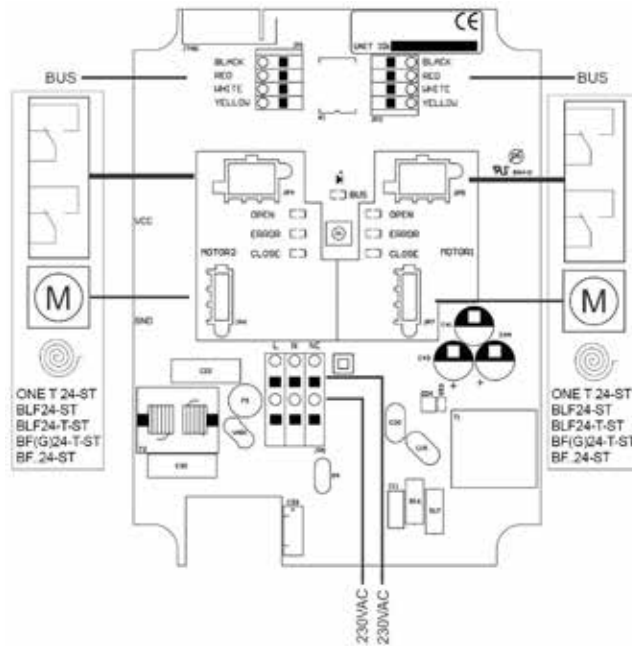

## DIMENSIONS AND MOUNTING

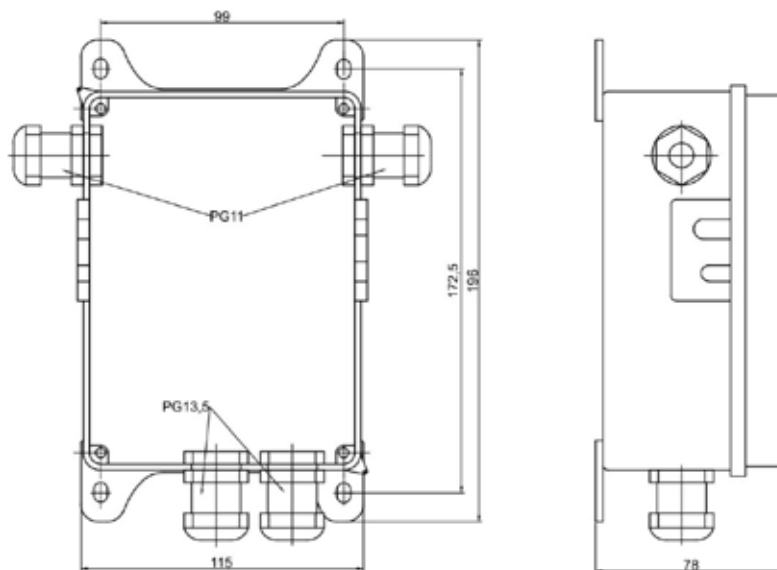

## SAFETY NOTES



- The device is not allowed to be used outside the specified field of application, especially in aircraft or in any other airborne means of transport.
- Caution: Power supply voltage!
- It may only be installed by suitably trained personnel. Any legal regulations or regulations issued by authorities must be observed during assembly.
- The device may only be opened at the manufacturer's site. It does not contain any parts that can be replaced or repaired by the user.
- The device contains electrical and electronic components and is not allowed to be disposed of as household refuse. All locally valid regulations and requirements must be observed.

If the product is manipulated in any other way than described, Rf-Technologies will decline any responsibility and the guarantee will immediately expire!

